

Dairy Case Depalletizing System



Use For:

- 16 quart plastic dairy cases on 40" x 40" pallets
- 24 quart plastic dairy cases on 40" x 48" pallets
- To reduce empty case receiving costs

Key Features:

- De-palletizes 2-3 pallets per minute feeding 4 top-out or 2 bottom-out high speed de-stackers (max. 63 cases/min. 16 qt; 49 cases/min. 24 qt)
- De-palletizes using clamp and lift technology without stack pushers, eliminating stack sway and tipping
- Automatic empty pallet stacking with optional pallet stack accumulation discharge conveyor
- Able to handle both palletized and non-palletized 9-stack groups
- Stainless steel construction
- Color touch screen operator HMI with 330 degree swivel mounting
- PLC controlled, ethernet compatible
- Modular construction enabling faster and easier installation
- Full wash down P-65 rating on all sensors, panels and motors

Options Available:

- Pallet stack discharge accumulation with operator alarm
- Detection and removal of stacks to spur line
- Pallet in-feed conveyor extensions for up to 20 pallet positions
- Twin lane pallet in-feed conveyor for additional accumulation
- Full safety guarding with light curtain protection



Our Innovation
Your Solution



Technical Specifications

Electrical requirements: 230/460/575 V, 3 ph, 50/60 Hz, 5.5 KW

Compressed air: 2 cfm @ 100 psi

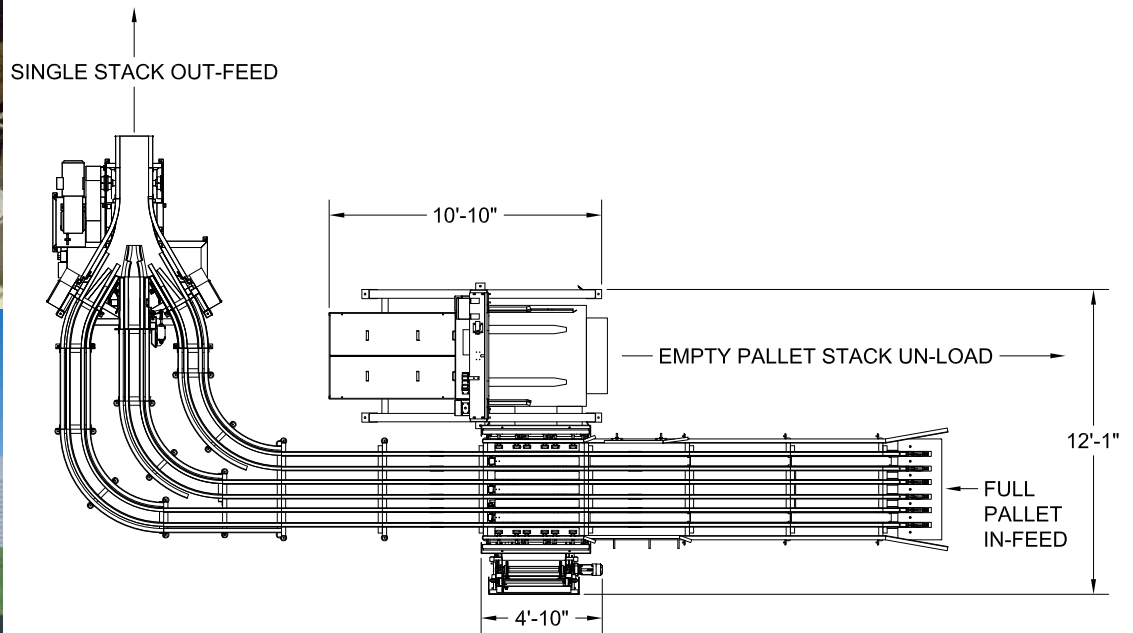

About Westfalia Technologies, Inc.

For 35 years, Westfalia Deam Systems has been a leader in providing customized case handling and case packing equipment designed to meet specific customer requirements. In addition to Deam case handling and packaging systems, Westfalia creates innovative material handling solutions to support customer distribution and storage needs. Westfalia's products include Automated Storage and Retrieval Systems (AS/RS), Conveying and Pallet Flow Systems, and Savanna.NET® Warehouse Management Systems software.



3655 Sandhurst Drive
York, PA 17406

Tel. 800-673-2522 / 717.764.1115

Fax 717.764.1118

email: sales@WESTFALIAUSA.com

www.WESTFALIAUSA.com

Other Equipment Available from Westfalia

To compliment this palletizing system, Westfalia Deam Systems can provide casers for packing all size bottles, jugs, cartons, etc. and case stacking/destacking systems, conveyors, case pushers/inverters, dolly loaders, automated cold storage systems (AS/RS) and Savanna.NET® Warehouse Management Software (WMS).

Empty Case Handling Systems

Case Pushers/Diverters/Inverters

Conveyor Systems - infeed and outfeed

Destacking Systems for multiple case sizes

Full Case Handling Systems

Cold Storage Systems

Palletizers and Unitizers

Stackers for multiple case sizes and speeds

Stack Pushers

Standard and Customized Conveyors

Case Packers and Product Conveyors

Creamer Cup Casers

Culture Product Casers

Custom-designed Casers

Gable Top Carton Casers for multiple sizes and speeds

Gallon and 1/2 Gallon Casers

NEW *High Speed Dual Station Caser*

NEW *Plastic Bottle Casers for multiple sizes and speeds*

System Integration

Cold Storage Automated Storage and Retrieval Systems(AS/RS)

Engineering Layout and Consulting

Turnkey Material Handling for plant upgrades and new plant projects

Savanna.NET® Warehouse Management Software