

Model 991C

Mechanical Right Angle Transfer

3-Way Extended Chain Conveyor Unit (Outboard Motor)

NOTE: Unit Shown has Non-Standard
Extended Roller Section

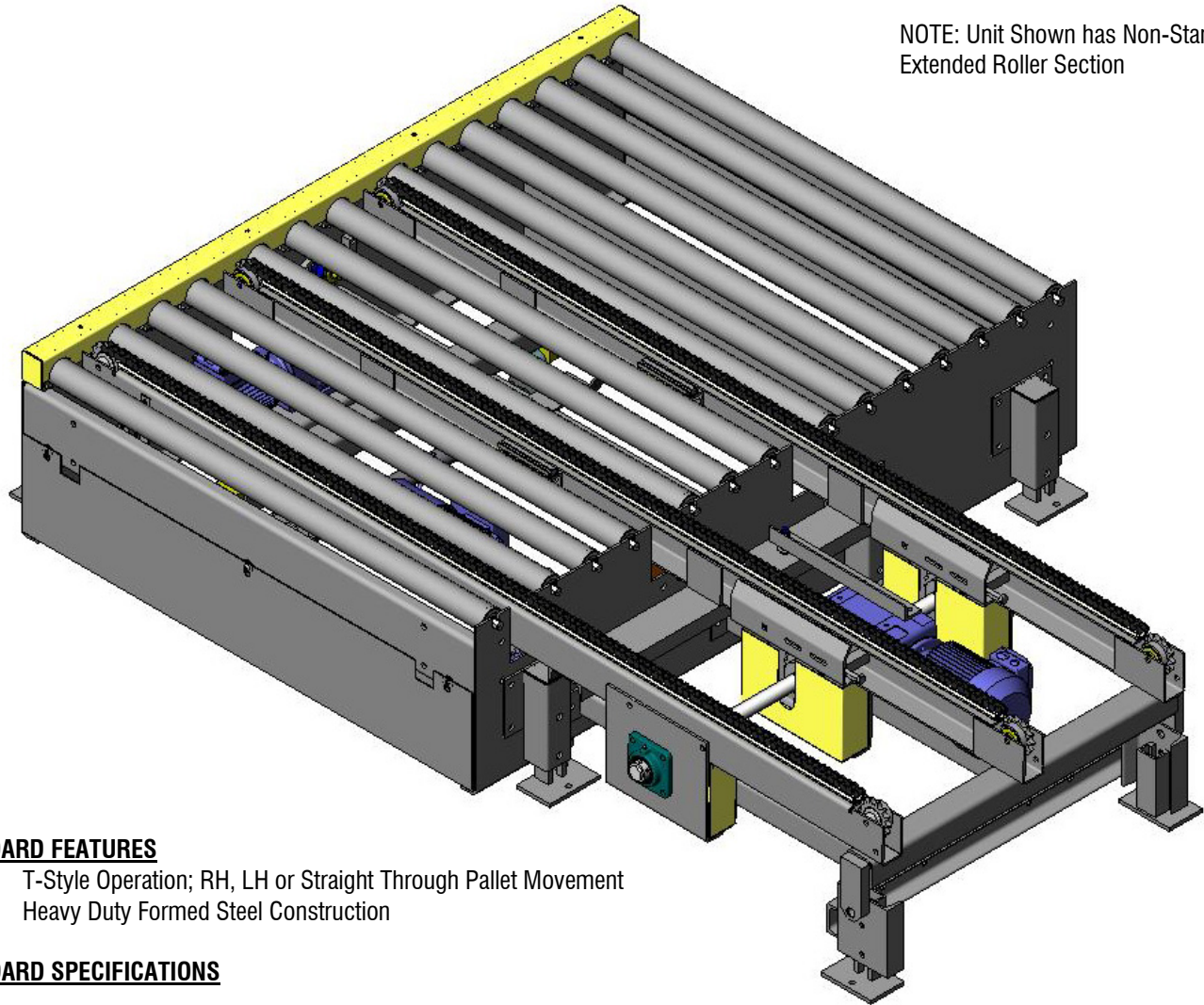

STANDARD FEATURES

- T-Style Operation; RH, LH or Straight Through Pallet Movement
- Heavy Duty Formed Steel Construction

STANDARD SPECIFICATIONS

- | | |
|------------------|---|
| • FRAME: | Heavy Duty Formed Steel |
| • SUPPORTS: | Heavy Duty Formed Steel Channel Floor Supports |
| • ROLLERS: | 2 1/2" Diameter on 4 13/16" Centers, Chain Driven |
| • CHAIN: | (3) #60 Transport Chains on UHMW Extrusion Wearstrip
Extended Length 3'-0" Minimum |
| • LIFT: | Cam Lift with Heavy Duty Cam Followers. Raise or Lower Cycle Time: 1.5 Seconds |
| • MOTORS: | 230/460V-3PH-60HZ T.E.F.C. |
| • SPEED: | 40 & 60 FPM Standard |
| • PALLET SIZE: | 40" x 48" Standard |
| • LOAD CAPACITY: | 3,500 Lbs. Maximum, 200 Lbs. Minimum |
| • FINISH: | Powder Coating, Color: Westfalia Gray RAL #7040 |