

Model 971D Pallet Squaring Station – USPS Pallets Three Strand Chain Pallet Conveyor

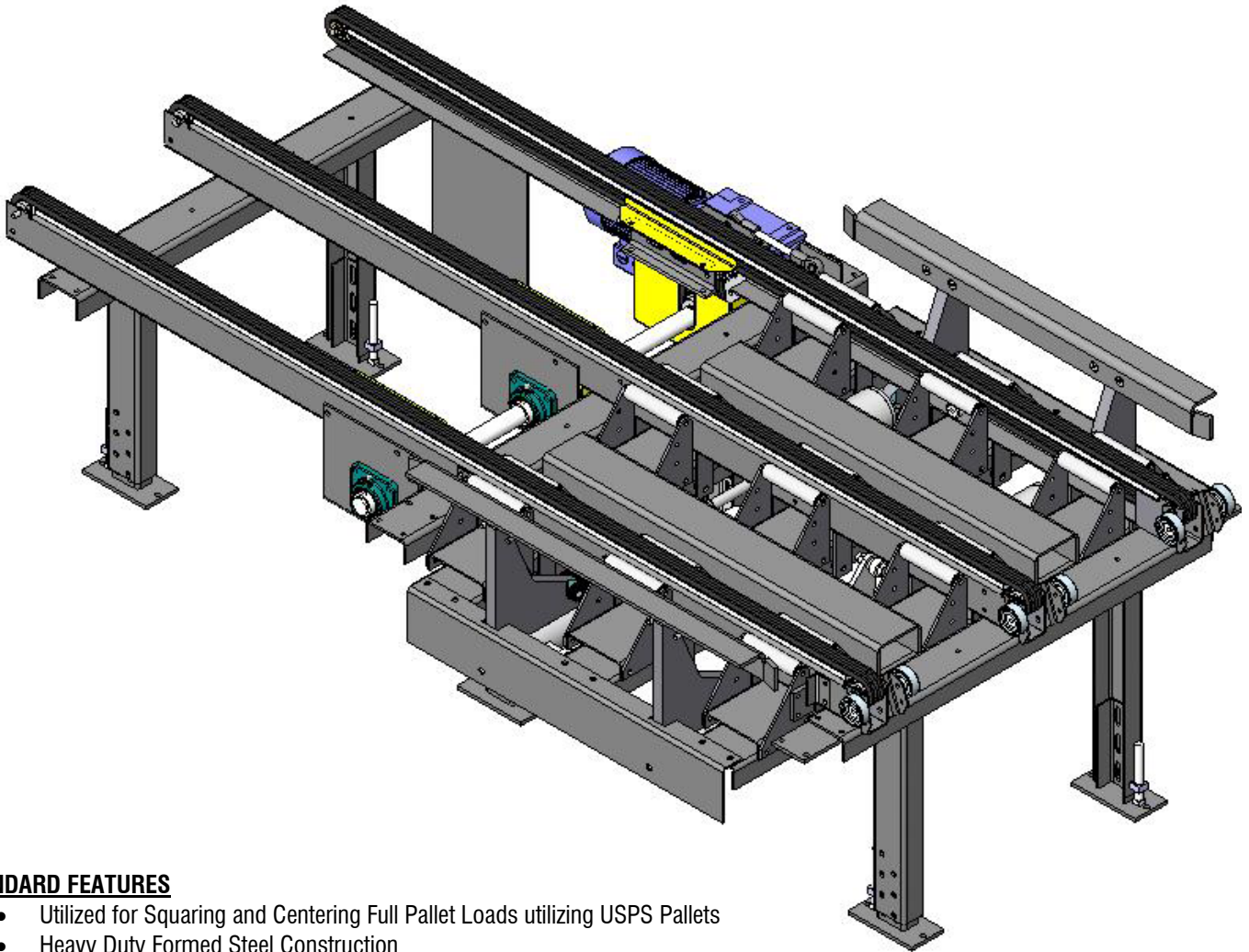

STANDARD FEATURES

- Utilized for Squaring and Centering Full Pallet Loads utilizing USPS Pallets
- Heavy Duty Formed Steel Construction

STANDARD SPECIFICATIONS

- | | |
|-------------------|---|
| • FRAME: | 7 Gauge Formed Steel Channel |
| • SUPPORTS | Heavy Duty Formed Steel Channel Floor Supports |
| • CHAIN: | Double #50 Roller Chain on UHMW Extrusion Wearstrip |
| • SQUARING ARMS: | Air Cylinder Actuated |
| • MOTOR: | 230/460V-3PH-60HZ T.E.F.C. |
| • SPEED: | 40, 60 or 80 FPM Standard |
| • PALLET SIZE: | 40" x 48" Standard |
| • LOAD CAPACITY: | 3,500 Lbs. |
| • NOMINAL LENGTH: | 9-0" Length |
| • FINISH: | Powder Coating, Color: Westfalia Gray RAL #7040 |