

# Model 941

## Shift Unit – Three Strand Chain Pallet Conveyor or CDLR Pallet Conveyor

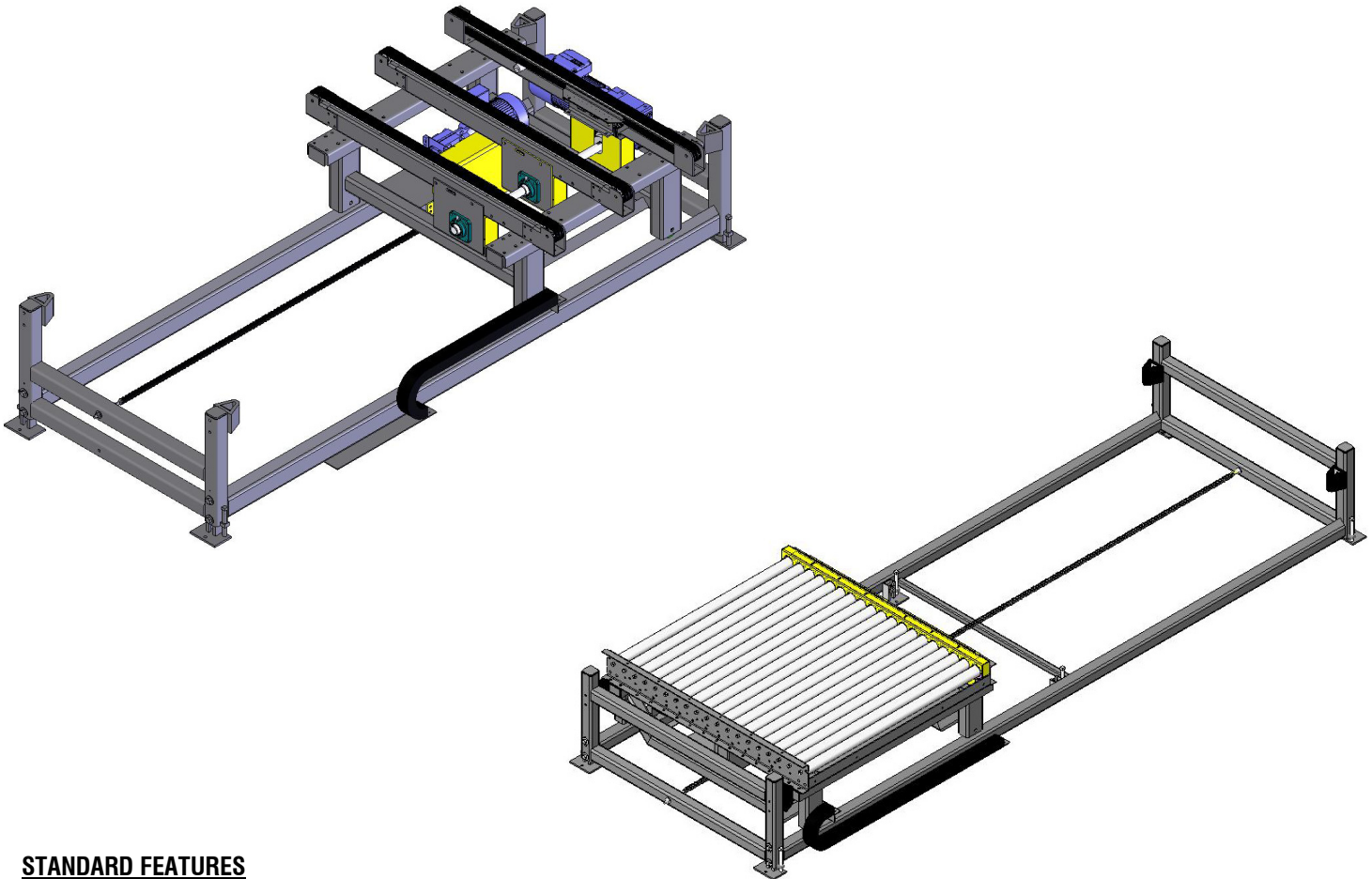

### STANDARD FEATURES

- Utilized for Conveying Pallets to (2) Different Locations/Conveyors

### STANDARD SPECIFICATIONS

- |                   |  |
|-------------------|--|
| • FRAME:          | 7 Gauge Formed Channel Steel   |
| • SUPPORTS:       | Heavy Duty Formed Steel Channel Floor Supports; 28" Minimum, 48" Maximum   |
| • CHAIN/CDLR:     | Model A - #60 Roller Chain on UHMW Extrusion Wearstrip (Model 938)<br>Model B - Double #50 Chain on UHMW Extrusion Wearstrip (Model 939)<br>Model C - CDLR with 6.25" Roller Centers (Model 927)<br>Model D - CDLR with 3.125" Roller Centers (Model 928)<br>Model E - CDLR with 4" Roller Centers (Model 929) |
| • MOTOR:          | 230/460V-3PH-60HZ T.E.F.C.   |
| • SPEED:          | 40, 60 or 80 FPM Standard for Conveyor   |
| • SHIFTING SPEED: | 40 FPM Standard  |
| • PALLET SIZE:    | 40" x 48" Standard   |
| • LOAD CAPACITY:  | 3,500 Lbs.   |
| • FINISH:         | Powder Coating, Color: Westfalia Gray RAL #7040  |