

## Model 926

# Three Strand with Double #50 Chain USPS Pallet Forktruck Pickup Conveyor

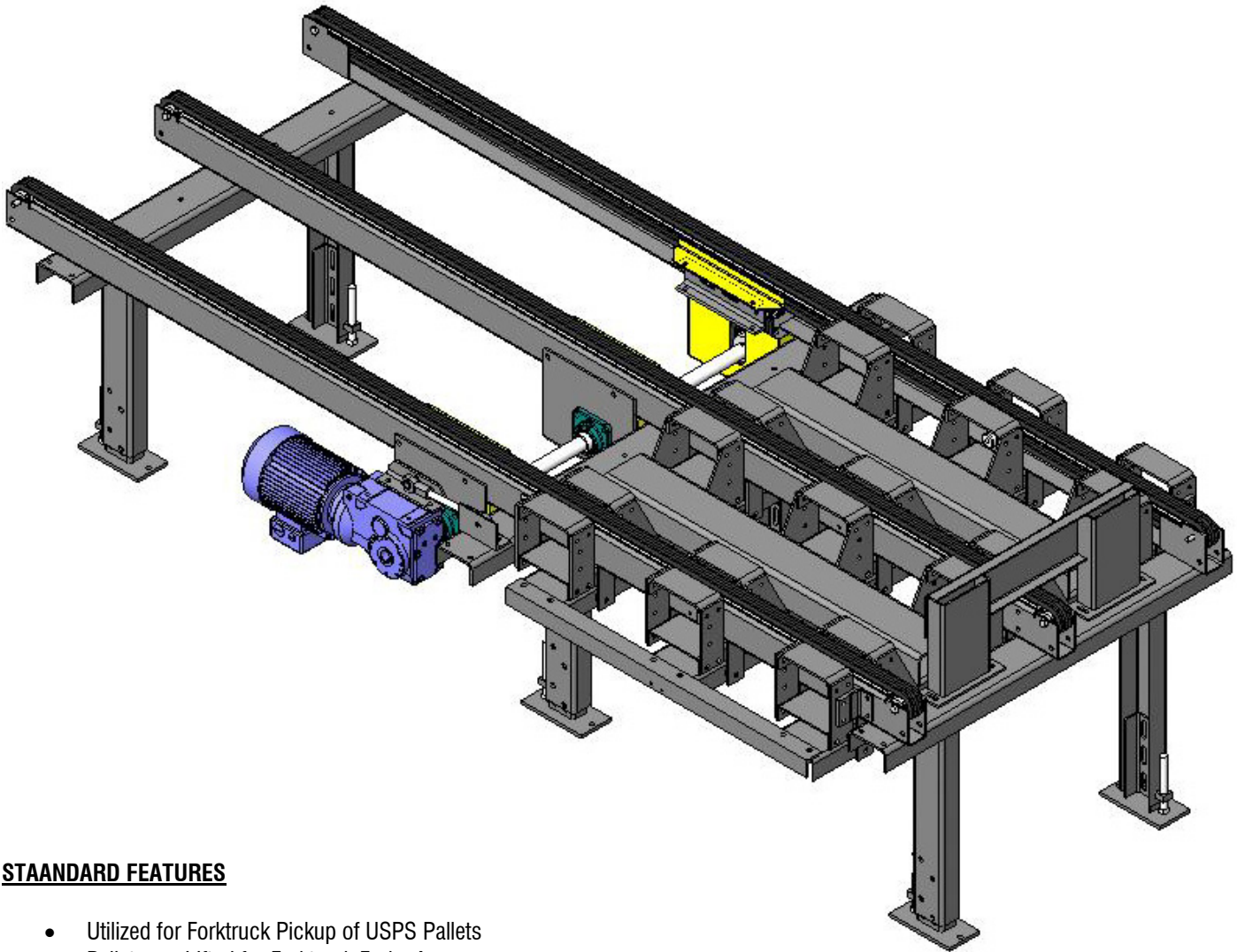

### STANDARD FEATURES

- Utilized for Forktruck Pickup of USPS Pallets
- Pallets are Lifted for Forktruck Forks Access

### STANDARD SPECIFICATIONS

- |                  |  |
|------------------|--|
| • FRAME:         | 7 Gauge Formed Channel Steel   |
| • SUPPORTS       | Heavy Duty Formed Steel Channel Floor Supports; 15" Minimum, 48" Maximum |
| • CHAIN:         | Double #50 Roller Chain on UHMW Extrusion Wearstrip                      |
| • MOTOR:         | 230/460V-3PH-60HZ T.E.F.C.   |
| • SPEED:         | 40, 60 & 80 FPM Standard   |
| • PALLET SIZE:   | 40" x 48" Standard   |
| • LOAD CAPACITY: | 3,500 Lbs. Maximum, 200 Lbs. Minimum                                     |
| • FINISH:        | Powder Coating, Color: Westfalia Gray RAL #7040                          |