

Model 820 Shift Conveyor

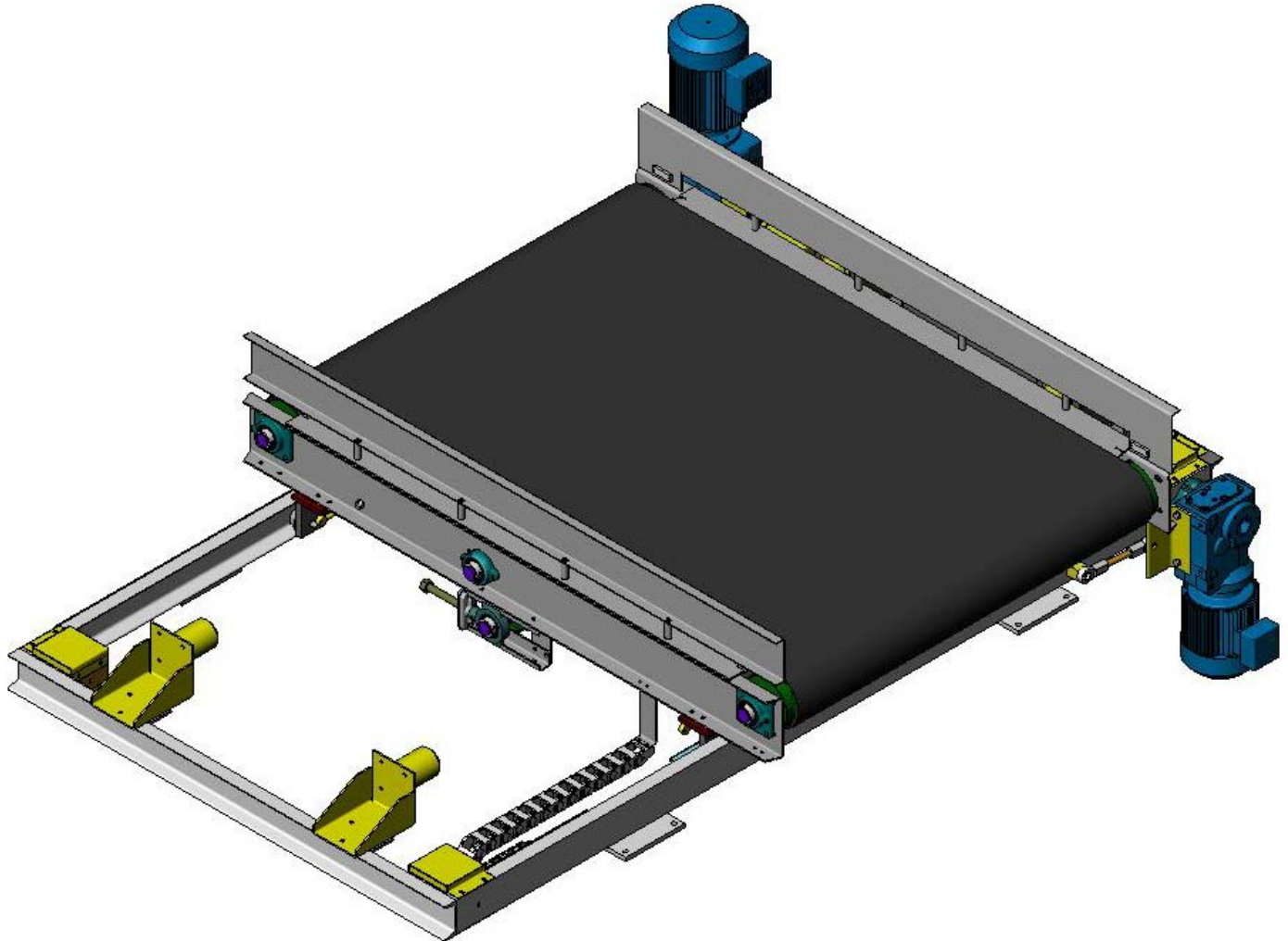

STANDARD FEATURES

- Utilized for Conveying Product to (2) Different Locations/Conveyors

STANDARD SPECIFICATIONS

- | | |
|--------------------|---|
| • FRAME: | 7 Gauge Formed Channel, 10 Gauge Steel Slider Bed |
| • SUPPORTS | Heavy Duty Welded 4" Formed Steel Channel with Adjustable Feet for $\pm 3"$ |
| • BELT: | Black Rough-Top |
| • PULLEYS: | 4" Diameter Crown Face, Infeed and Discharge Ends |
| • SHIFT MECHANISM: | Electric Motor Driven on (2) Slide Rails |
| • MOTORS: | 230/460V-3PH-60HZ T.E.F.C. |
| • SPEED: | 65, 80 and 100 FPM Standard |
| • FINISH: | Powder Coating, Color: Westfalia Gray RAL #7040 |