

## Model 523

# 90° Bag Transfer Conveyor with Pneumatic Kicker

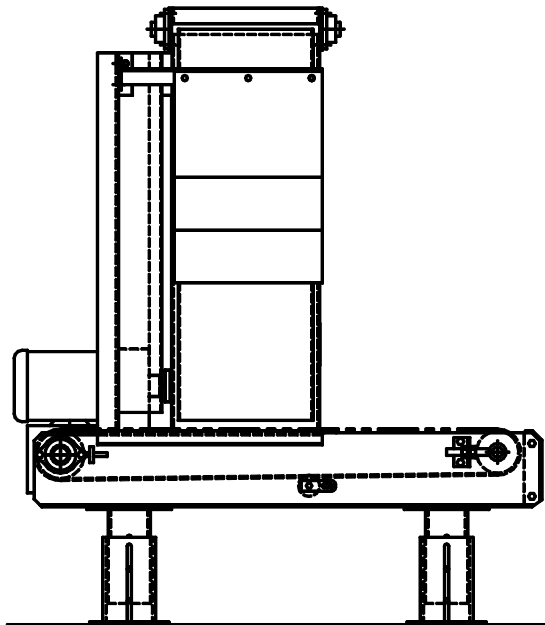
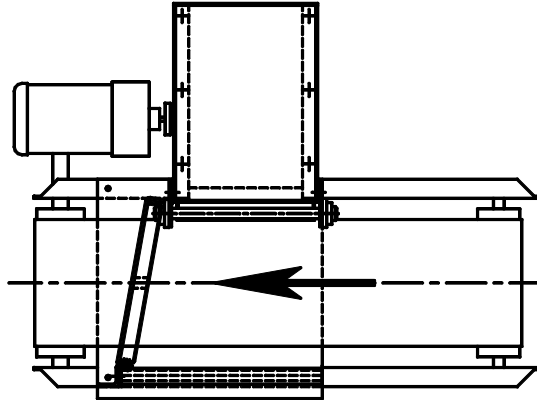

### STANDARD SPECIFICATIONS

- FRAME: 7" Deep Formed Channel, 7 Gauge Steel
- SUPPORTS: Heavy Duty Welded 4" Formed Steel Channel with Adjustable Feet for  $\pm 3"$
- BELT: Interwoven Polyester with PVC Cover, 120 P.I.W.
- PULLEYS: 4" Nominal Diameter Both Ends
- ROLLERS: 1.9" Diameter Rollers with Ball Bearings, 7/16" Diameter Shaft, Nominally Spaced on 4" Centers
- LENGTH: 3' Long Model A – 4' Long Model B
- MOTOR: 230/460V-3PH-60HZ T.E.F.C.
- SPEED: 65 FPM Standard
- FINISH: Powder Coating, Color: Westfalia Gray RAL #7040