

Model 421 In-Line Electric Reject/Transfer Unit

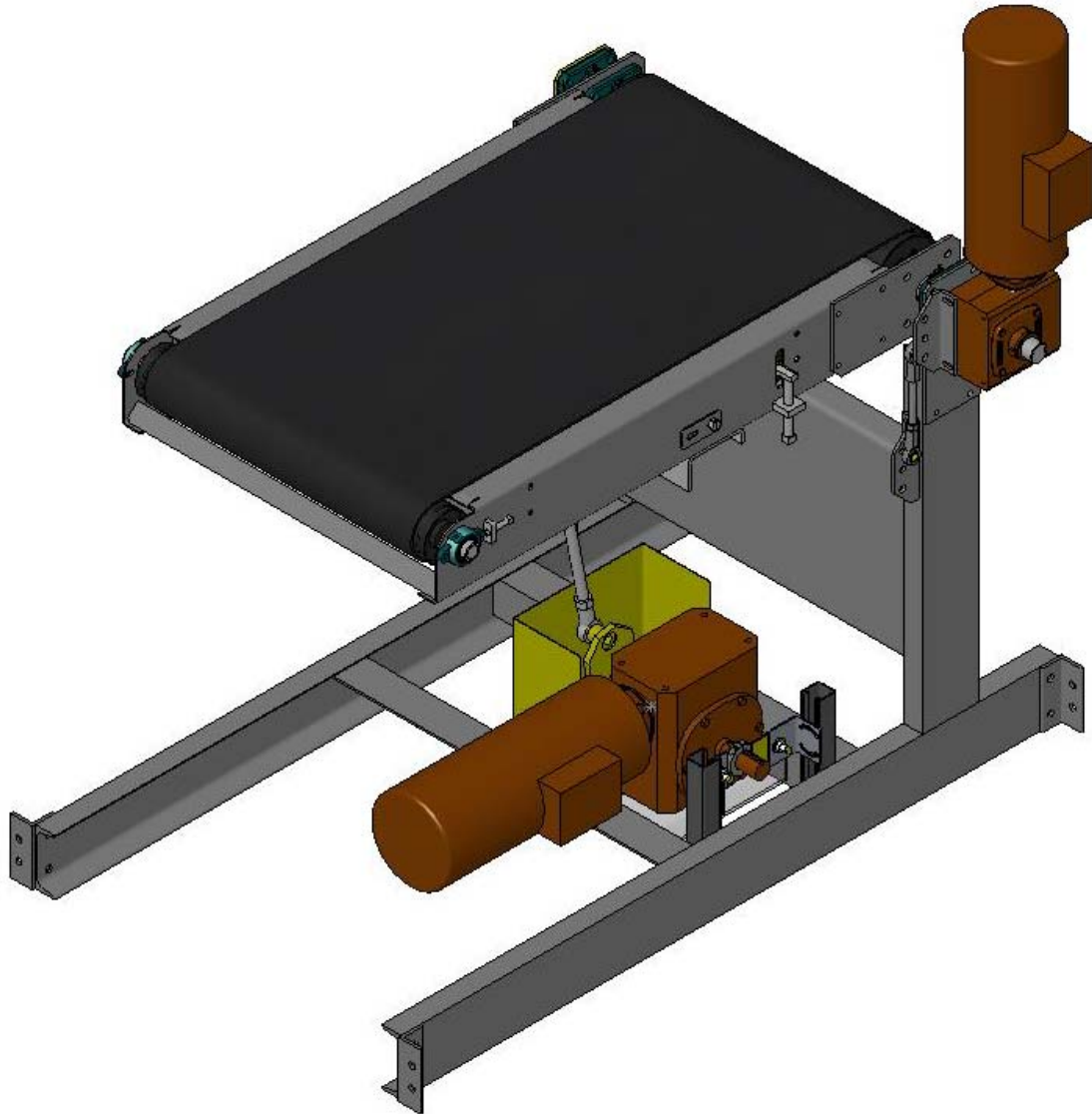

STANDARD SPECIFICATIONS

- FRAME: 7 Gauge Formed Channel, 10 Gauge Steel Slider Bed
- SUPPORTS: Heavy Duty Welded 4" Formed Steel Channel with Adjustable Feet for $\pm 3"$
- BELT: 24 Wide Black Rough-Top
- PULLEYS: 4" Diameter Crown Face Feed End Pulley
4" or 6" Diameter Crown Face Lagged Head End Pulley
- MOTOR: 230/460V-3PH-60HZ T.E.F.C.
- SPEED: 50, 60, 75 or 100 FPM Nominal Standard
- BAG REJECT SPEED: Up to 30 BPM
- FINISH: Powder Coating, Color: Westfalia Gray RAL #7040