

Model 410D

Bag Flattener Conveyor – Horizontal to 20° Incline

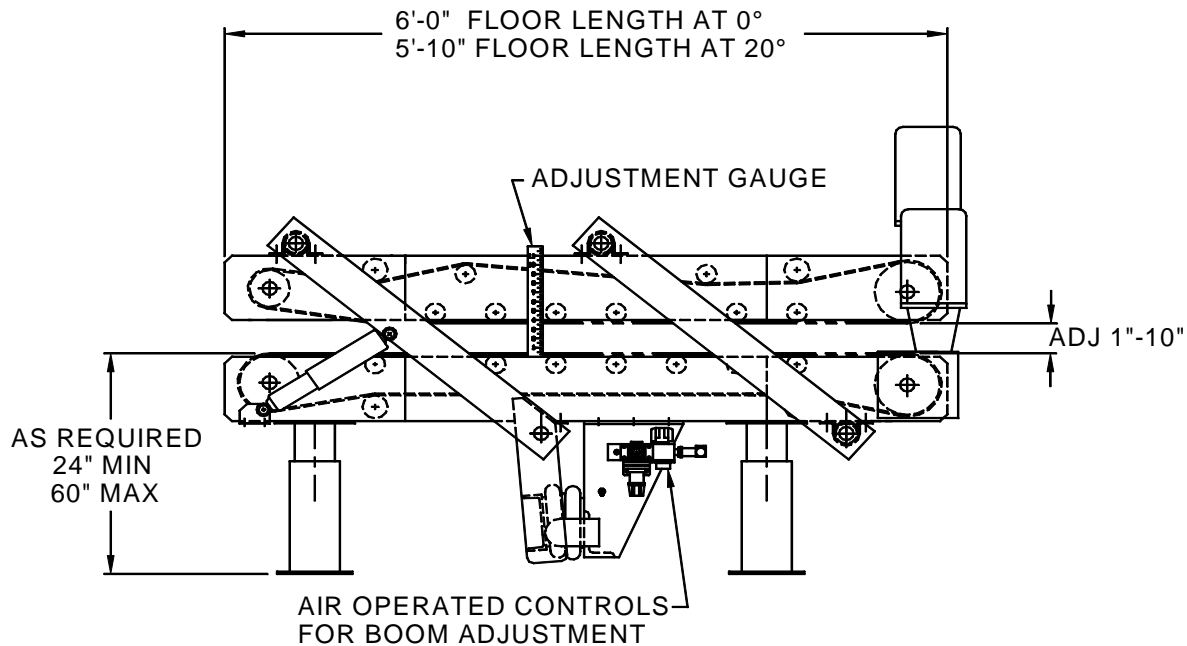

Note:

- Maximum Rise of Flattener at Maximum Incline is 22"

STANDARD SPECIFICATIONS

- **FRAME:** 7 Gauge Formed Channel Sides
- **SUPPORTS:** Heavy Duty Welded 4" Formed Steel Channel with Adjustable Feet for $\pm 3"$
- **BELT:** 24" Wide Black Rough-Top
- **ROLLERS:** 1.9" Diameter Rollers with Ball Bearings, 7/16" Diameter Shaft, Nominally Spaced on 6" Centers
- **PULLEYS:** 6" Diameter Crown Face Feed End Pulley
6" or 8" Diameter Crown Face Lagged Head End Pulley
- **TAKE-UP:** Feed End Belt Take-Up Adjustable by Stainless Steel Take-Up Screws
- **FLATTENING BOOM ADJUSTMENT:** Air Operated, 80 PSI Maximum
- **E-STOPS:** NEMA12 String E-Stops are Installed on each Side of the Flattener for Safety
- **MOTORS:** 230/460V-3PH-60HZ T.E.F.C.
- **SPEED:** 50, 60, 75 or 100 FPM Nominal Standard
- **FINISH:** Powder Coating, Color: Westfalia Gray RAL #7040

