

Pouch Pack Milk Bag Caser



Use For:

- 4 liter/gallon milk bags
- Case packs 4 bags
- Square plastic dairy cases

Key Features: Model ACII-C

- Loads single case per cycle with 4 bags
- Operating speeds up to 80 bags/minute
- Packing patterns of 1 x 4
- Stainless steel construction
- PLC controls and air valves within Nema 4/4x stainless enclosure
- Push button and selector switch operator panel
- Beacon light indicates caser operation mode
- Compact design with four position bag infeed orientation
- New infeed diverter design and improved safety guarding
- Added communications features with filler, bagger and stacker line components
- Extended warranty coverage with service agreement

Options Available:

- Infeed bag conveyor from filler
- Motor starter panel for bag infeed conveyor
- HMI color touch screen on 180 swivel mount
- Bag synchronization system to handle two filler lines
- **Model # ACIII-C for rectangular dairy cases-6 bags per case**
- Powder filled bags
- Corrugated case loading
- Case conveyor to accommodate plant layout



Our Innovation
Your Solution



Technical Specifications

Electrical requirements: 120V, single phase

Compressed air: 0.5 cfm @ 80 psi

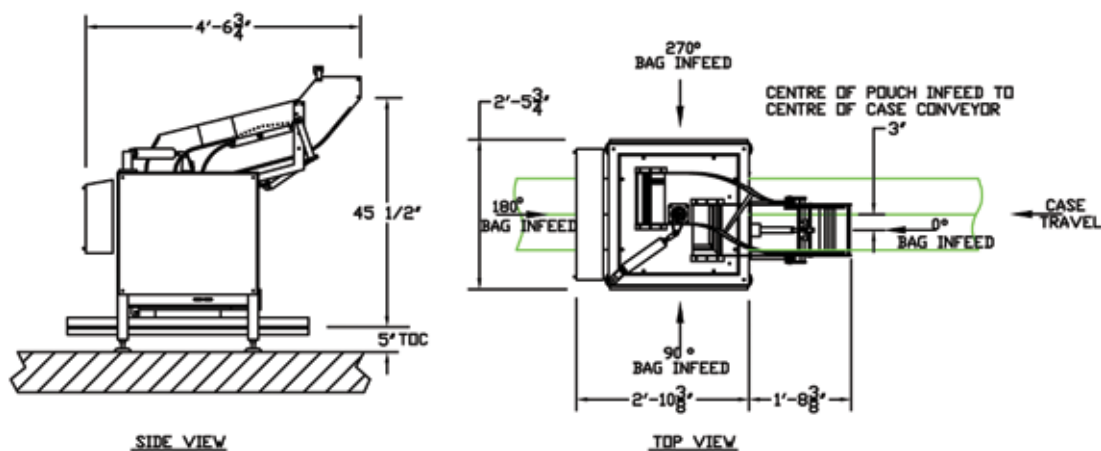

About Westfalia Technologies, Inc.

For 35 years, Westfalia Deam Systems has been a leader in providing customized case handling and case packing equipment designed to meet specific customer requirements. In addition to Deam case handling and packaging systems, Westfalia creates innovative material handling solutions to support customer distribution and storage needs. Westfalia's products include Automated Storage and Retrieval Systems (AS/RS), Conveying and Pallet Flow Systems, and Savanna.NET® Warehouse Management Systems software.



3655 Sandhurst Drive
York, PA 17406

Tel. 800-673-2522 / 717.764.1115

Fax 717.764.1118

email: sales@WESTFALIAUSA.com

www.WESTFALIAUSA.com

Other Equipment Available from Westfalia

To complement this casing system, Westfalia Deam Systems can provide case stacking/destacking systems, jug and case conveyors, case pushers/inverters, palletizers, dolly loaders, automated cold storage systems (AS/RS) and Savanna.NET® Warehouse Management System (WMS) software.

Empty Case Handling Systems

Case Pushers/Diverters/Inverters

Conveyor Systems

Destacking Systems for multiple case sizes

Full Case Handling Systems

Cold Storage Systems

Palletizers and Unitizers

Stackers for multiple case sizes and speeds

Stack Pushers

Standard and Customized Conveyors

Case Packers and Product Conveyors

Creamer Cup Casers

Culture Product Casers

Custom-designed Casers

Gable Top Carton Casers for multiple sizes and speeds

Gallon and 1/2 Gallon Casers

NEW *High Speed Dual Station Caser*

NEW *Plastic Bottle Casers for multiple sizes and speeds*

System Integration

Cold Storage Automated Storage and Retrieval Systems (AS/RS)

Engineering Layout and Consulting

Turnkey Material Handling for plant upgrades and new plant projects

Savanna.NET® Warehouse Management Software