



## QUESTIONNAIRE FOR CONVEYOR SYSTEMS

### CUSTOMER INFORMATION

COMPANY NAME: \_\_\_\_\_ PHONE: \_\_\_\_\_  
 CONTACT: \_\_\_\_\_ FAX: \_\_\_\_\_  
 TITLE: \_\_\_\_\_ EMAIL: \_\_\_\_\_  
 ADDRESS: \_\_\_\_\_ JOB SITE ADDRESS: \_\_\_\_\_  
 \_\_\_\_\_ (IF DIFFERENT) \_\_\_\_\_  
 ZIP CODE: \_\_\_\_\_ ZIP CODE: \_\_\_\_\_

WHAT TYPE OF PROPOSAL DO YOU NEED?: \_\_\_\_\_ SKETCH & BUDGET \_\_\_\_\_ FORMAL PROPOSAL

WHEN IS THE PROPOSAL DUE?: \_\_\_\_\_ (INCLUDE RFQ & PROJECT SPECS)

WHEN WILL THE PROJECT START?: \_\_\_\_\_ WITHIN NEXT 3 MONTHS \_\_\_\_\_ WITHIN NEXT 6 MONTHS  
 \_\_\_\_\_ WITHIN 1 YEAR \_\_\_\_\_ 1 YEAR OR MORE

WILL WORK ON THE PROJECT BE UNION OR NON-UNION?: \_\_\_\_\_

ARE INSTALLATION CONTRACTORS REQUIRED TO BE LICENSED IN YOUR STATE?: \_\_\_\_\_

OTHER THAN ENGLISH, IN WHICH LANGUAGE DO YOU PREFER TO RECEIVE COMMUNICATION?: \_\_\_\_\_

WHICH UNIT OF MEASURE DO YOU PREFER?: \_\_\_\_\_ ENGLISH (0'-0", lbs) \_\_\_\_\_ METRIC (mm,kg)

### PALLET INFORMATION

CHECK ALL THAT APPLY:

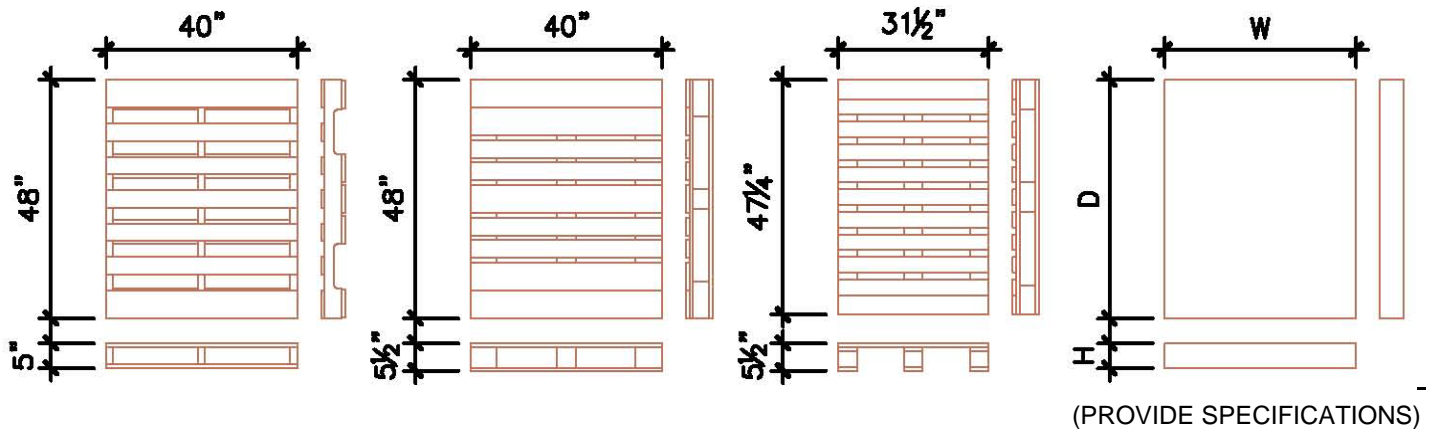

## LOAD INFORMATION

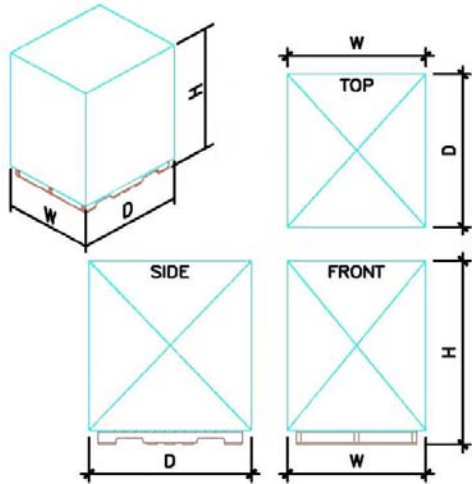

MAXIMUM LOAD SIZE (INCLUDE PALLET, OVERHANG & SKEW):

MAXIMUM WIDTH (W): \_\_\_\_\_

MAXIMUM DEPTH (D): \_\_\_\_\_

MAXIMUM HEIGHT (H): \_\_\_\_\_

MAXIMUM WEIGHT: \_\_\_\_\_

MINIMUM WEIGHT: \_\_\_\_\_

TYPE OF PRODUCT IS BEING CONVEYED? \_\_\_\_\_

IS LOAD STRETCH WRAPPED? \_\_\_\_\_

HOW MUCH OF THE LOAD IS WRAPPED? \_\_\_\_\_

HOW IS THE LOAD STACKED? \_\_\_\_\_

IS THE LOAD STABLE? \_\_\_\_\_

## BASIC THROUGHPUT DATA

HOURS PER SHIFT: \_\_\_\_\_

SHIFTS PER DAY: \_\_\_\_\_

DAYS PER WEEK: \_\_\_\_\_

MAXIMUM PALLET LOADS PER HOUR		
SHIFT 1	SHIFT 2	SHIFT 3

## ENVIRONMENTAL CONDITIONS

IS THIS AN AMBIENT, COOLER OR FREEZER APPLICATION?:

AREA 1 _____ °F MIN _____ °F MAX	AREA 2 _____ °F MIN _____ °F MAX	OTHER: _____ °F MIN _____ °F MAX
-------------------------------------	-------------------------------------	-------------------------------------

SPECIAL CONDITIONS (HUMIDITY, CAUSTIC CHEMICALS, DUST, WASHDOWN, ETC.): \_\_\_\_\_

HAZARDOUS ENVIRONMENT? (CLASS/DIVISION/GROUP): \_\_\_\_\_

**COMPRESSED AIR** (IF REQUIRED BY WESTFALIA FOR AIR-ZONE ACCUMULATION CONVEYORS)

---

COMPRESSED AIR AVAILABLE ? \_\_\_\_\_

AIR DROPS / INTERFACES DEFINED AND WHERE?: \_\_\_\_\_

PIPE DIAMETER, VALVES?: \_\_\_\_\_

---

**ELECTRICAL INFORMATION**

---

WHAT ELECTRICAL POWER SOURCE WILL BE AVAILABLE?: \_\_\_\_\_ VOLTS \_\_\_\_\_ HZ

ANY SPECIAL CONDUIT REQUIREMENTS?: \_\_\_\_\_

WILL EMT CONDUIT BE PERMITTED?: \_\_\_\_\_

WILL THERE BE A CENTRALIZED ROOM FOR CONTROL PANELS?: \_\_\_\_\_

ELECTRICAL POWER DROPS / INTERFACES DEFINED AND WHERE?: \_\_\_\_\_

---

DO YOU REQUIRE UL508A CONTROL PANELS?: \_\_\_\_\_ NEMA OR IP RATING?: \_\_\_\_\_

DO YOU HAVE A SPECIAL CONTROLS OR ELECTRICAL SPECIFICATION FOR WESTFALIA TO FOLLOW?: \_\_\_\_\_

**MISCELLANEOUS SPECIAL EQUIPMENT & ACCESSORIES**

---

POWDER COATED FINISH: (STATE COLOR W/RAL # IF OTHER THAN WTI STANDARD GRAY) \_\_\_\_\_

WILL THE WESTFALIA SYSTEM NEED TO ADJOIN OTHER CONVEYANCE SYSTEMS?: \_\_\_\_\_

WHAT EQUIPMENT WILL BE USED TO INTERFACE THE SYSTEM INPUT (Forktruck, Pallet Jack, etc.)?: \_\_\_\_\_

WHAT EQUIPMENT WILL BE USED TO INTERFACE THE SYSTEM OUTPUT (Forktruck, Pallet Jack, etc.)?: \_\_\_\_\_

PLEASE LIST ANY ADDITIONAL EQUIPMENT, ACCESSORIES OR SERVICES YOU WISH WESTFALIA TO PROVIDE: (Stretch Wrappers, Lifts, Maintenance Agreements, etc.)

---

---

---

---

---

---

