



QUESTIONNAIRE FOR CONVEYOR SYSTEMS

CUSTOMER INFORMATION

COMPANY NAME: _____ PHONE: _____
 CONTACT: _____ FAX: _____
 TITLE: _____ EMAIL: _____
 ADDRESS: _____ JOB SITE ADDRESS: _____
 _____ (IF DIFFERENT) _____
 ZIP CODE: _____ ZIP CODE: _____

WHAT TYPE OF PROPOSAL DO YOU NEED?: _____ SKETCH & BUDGET _____ FORMAL PROPOSAL _____

WHEN IS THE PROPOSAL DUE?: _____ (INCLUDE RFQ & PROJECT SPECS)

WHEN WILL THE PROJECT START?: _____ WITHIN NEXT 3 MONTHS _____ WITHIN NEXT 6 MONTHS _____
 _____ WITHIN 1 YEAR _____ 1 YEAR OR MORE _____

WILL WORK ON THE PROJECT BE UNION OR NON-UNION?: _____

ARE INSTALLATION CONTRACTORS REQUIRED TO BE LICENSED IN YOUR STATE?: _____

OTHER THAN ENGLISH, IN WHICH LANGUAGE DO YOU PREFER TO RECEIVE COMMUNICATION?: _____

WHICH UNIT OF MEASURE DO YOU PREFER?: _____ ENGLISH (0'-0", lbs) _____ METRIC (mm,kg) _____

PALLET INFORMATION

CHECK ALL THAT APPLY:

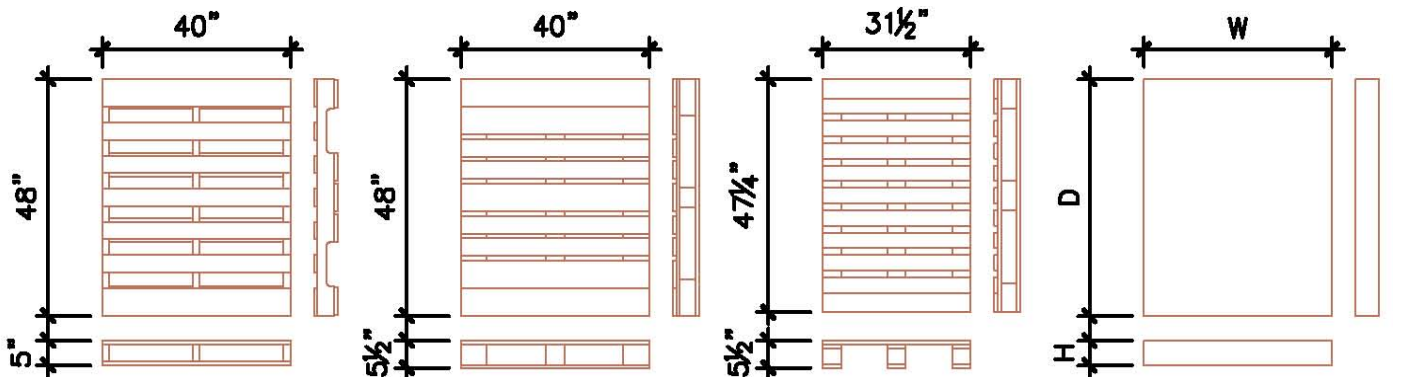

(PROVIDE SPECIFICATIONS)

LOAD INFORMATION

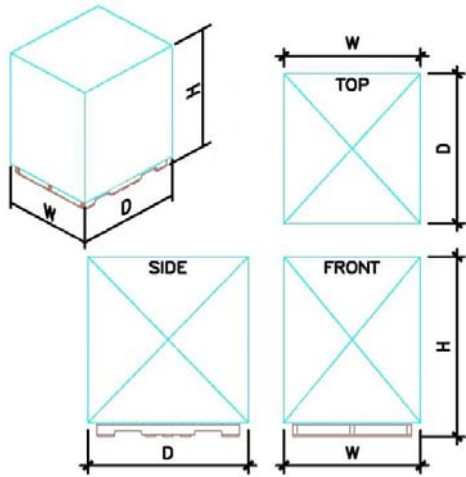

MAXIMUM LOAD SIZE (INCLUDE PALLET, OVERHANG & SKEW):

MAXIMUM WIDTH (W): _____

MAXIMUM DEPTH (D): _____

MAXIMUM HEIGHT (H): _____

MAXIMUM WEIGHT: _____

MINIMUM WEIGHT: _____

TYPE OF PRODUCT IS BEING CONVEYED? _____

IS LOAD STRETCH WRAPPED? _____

HOW MUCH OF THE LOAD IS WRAPPED? _____

HOW IS THE LOAD STACKED? _____

IS THE LOAD STABLE? _____

BASIC THROUGHPUT DATA

HOURS PER SHIFT: _____

SHIFTS PER DAY: _____

DAYS PER WEEK: _____

MAXIMUM PALLET LOADS PER HOUR		
SHIFT 1	SHIFT 2	SHIFT 3

ENVIRONMENTAL CONDITIONS

IS THIS AN AMBIENT, COOLER OR FREEZER APPLICATION?:

AREA 1 _____ °F MIN _____ °F MAX	AREA 2 _____ °F MIN _____ °F MAX	OTHER: _____ °F MIN _____ °F MAX
-------------------------------------	-------------------------------------	-------------------------------------

SPECIAL CONDITIONS (HUMIDITY, CAUSTIC CHEMICALS, DUST, WASHDOWN, ETC.): _____

HAZARDOUS ENVIRONMENT? (CLASS/DIVISION/GROUP): _____

COMPRESSED AIR (IF REQUIRED BY WESTFALIA FOR AIR-ZONE ACCUMULATION CONVEYORS)

COMPRESSED AIR AVAILABLE ? _____

AIR DROPS / INTERFACES DEFINED AND WHERE?: _____

PIPE DIAMETER, VALVES?: _____

ELECTRICAL INFORMATION

WHAT ELECTRICAL POWER SOURCE WILL BE AVAILABLE?: _____ VOLTS _____ HZ

ANY SPECIAL CONDUIT REQUIREMENTS?: _____

WILL EMT CONDUIT BE PERMITTED?: _____

WILL THERE BE A CENTRALIZED ROOM FOR CONTROL PANELS?: _____

ELECTRICAL POWER DROPS / INTERFACES DEFINED AND WHERE?: _____

DO YOU REQUIRE UL508A CONTROL PANELS?: _____ NEMA OR IP RATING?: _____

DO YOU HAVE A SPECIAL CONTROLS OR ELECTRICAL SPECIFICATION FOR WESTFALIA TO FOLLOW?: _____

MISCELLANEOUS SPECIAL EQUIPMENT & ACCESSORIES

POWDER COATED FINISH: (STATE COLOR W/RAL # IF OTHER THAN WTI STANDARD GRAY) _____

WILL THE WESTFALIA SYSTEM NEED TO ADJOIN OTHER CONVEYANCE SYSTEMS?: _____

WHAT EQUIPMENT WILL BE USED TO INTERFACE THE SYSTEM INPUT (Forktruck, Pallet Jack, etc.)?: _____

WHAT EQUIPMENT WILL BE USED TO INTERFACE THE SYSTEM OUTPUT (Forktruck, Pallet Jack, etc.)?: _____

PLEASE LIST ANY ADDITIONAL EQUIPMENT, ACCESSORIES OR SERVICES YOU WISH WESTFALIA TO PROVIDE: (Stretch Wrappers, Lifts, Maintenance Agreements, etc.)

